

D&E 'adeco' gate closer

CI/SfB		
31	49	
September 2007		

- The DC2600 can be installed at the top, middle or bottom of the gate on the 'PULL' side only.
- The face of the gate must be flush with the face of the gatepost.
- The gate should be hinged as close to the gate post as possible.
- The pivot point of the closer must be inline with the centre pivot line of the hinges. It may be necessary to fabricate a bracket or spacer to allow the closer to be installed correctly.
- The gate must swing freely on its hinges prior to installing the closer and the hinges must be greased regularly.
- The guide roller must be fitted. It may be necessary to fabricate a bracket / spacer to mount receive the guide roller.
- The gate must not be allowed to be opened more than 90°. If this is a possibility then a floor mounted door / gate stop should be installed.
- The holding pin (see fig. 4) must not be removed until the closer is fitted.

Maximum Gate Weight: 50Kgs / Maximum Gate Width: 1000mm

2: Remove the end cap and slide the closer on to the guide roller. Replace the end cap.

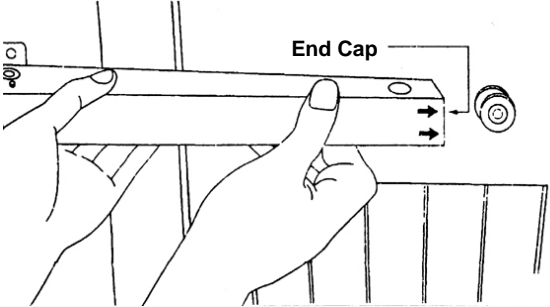

1: From the centre pivot line of the hinges, measure 222mm and secure the guide roller to the gate. This will line up with the locating marks which are on the body of the closer.

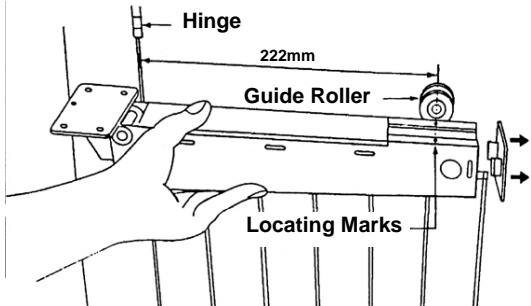

3: Secure the mounting bracket to the gate post with the four (4) screws supplied.

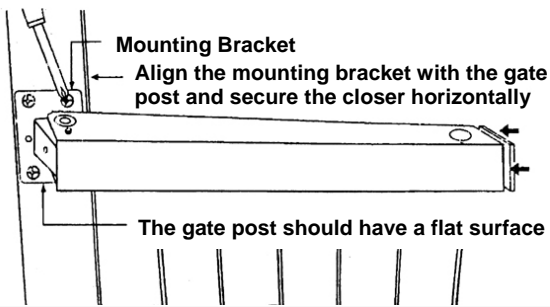

Align the mounting bracket with the gate post and secure the closer horizontally

The gate post should have a flat surface

4: Open the gate slowly until the holding pin either drops out or can be removed easily. If the holding pin is not removed prior to operating the gate, then the gate will not open and damage the closer may occur.

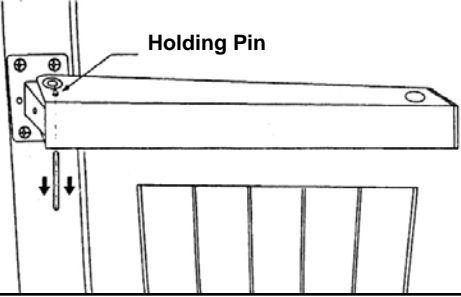

5: Holding the door open at about 45°, you can adjust the closing speed as required. Adjustment is via a screwdriver and should be in ¼ turn increments clockwise or anti-clockwise for a slower or faster closing action.

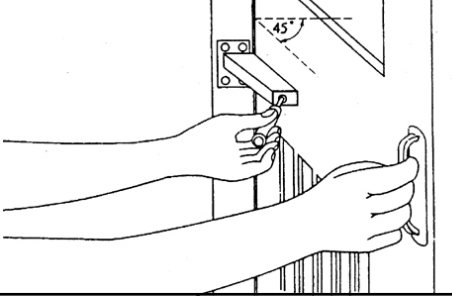

6: With the gate in the closed position, the final latching speed can be adjusted in the same manner as part 5 of these instructions.

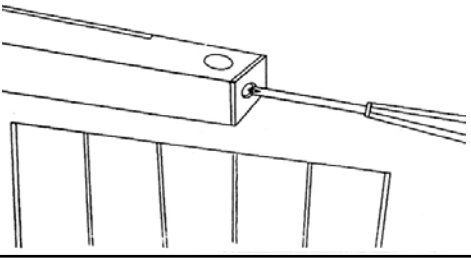

7: To engage the hold-open function, simply remove the screw from hole 'A' and screw it into hole 'B' for safe keeping. To remove the hold open function simply reverse this procedure. Do not force the closer beyond the screw as doing so will damage the closer.

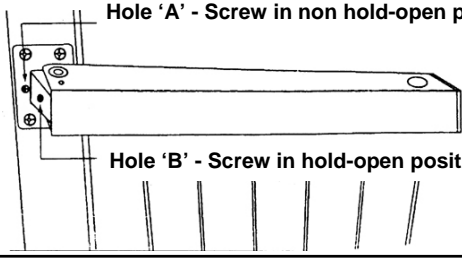

Hole 'A' - Screw in non hold-open position

Hole 'B' - Screw in hold-open position

© D&E Architectural Hardware Ltd - September 2007

